

*Розроблено мехатронну систему для комплексної оцінки та адаптації експлуатаційних параметрів вібраційної машини для приготування сипучих сумішей. Дана система містить блок активного аналізу динамічного стану коливної системи та блок керування приводним механізмом вібромашини. Функціональна взаємодія вищезначених блоків, залежно від типу сировини, забезпечує самостійну адаптацію вібромашини до технологічно оптимальних параметрів її роботи*

*Ключові слова: вплив вібрації на процес змішування, сипкий матеріал, система керування, оптимальні режимні параметри вібромашини*

*Разработана мехатронная система для комплексной оценки и адаптации эксплуатационных параметров вибрационной машины для приготовления сыпучих смесей. Данная система содержит блок активного анализа динамического состояния колеблющейся системы и блок управления приводным механизмом вибромашины. Функциональное взаимодействие вышеуказанных блоков, в зависимости от типа сырья, обеспечивает самостоятельную адаптацию вибромашины к технологически оптимальным параметрам ее работы*

*Ключевые слова: влияние вибрации на процесс смешивания, сыпучий материал, система управления, оптимальные режимные параметры вибромашины*

UDC 629.3.03:62-837

DOI: 10.15587/1729-4061.2017.117635

# DESIGN OF THE SYSTEM TO CONTROL A VIBRATORY MACHINE FOR MIXING LOOSE MATERIALS

**V. Yanovych**

PhD, Associate Professor

Department of processes and equipment for remaking and food production\*

E-mail: Yanovichvitaliy@i.ua

**T. Honcharuk**

PhD, Associate Professor

Department of agrarian management\*

E-mail: Tana.Honcharuk@gmail.com

**I. Honcharuk**

PhD, Associate Professor

Department of economics\*

E-mail: dnistervnau2017@gmail.com

**K. Kovalova**

PhD, Associate Professor

Department of Ukrainian and foreign languages\*

E-mail: katrin.viter@gmail.com

\*Vinnytsia National Agrarian University

Soniachna str., 3, Vinnytsia, Ukraine, 21008

## 1. Introduction

A characteristic feature of world development of information technologies in the late XX and the beginning of the XXI century is the selection of integrally-created (comprehensive) technologies, which include the technology of micromechanical systems. At present, there is a growing interest worldwide in the design of integrated sensors, which make it possible to create various systems in order to control technological processes. Efficiency of these processes depends on the orderliness of technological operations and design features of machinery for their implementation.

Among the basic processes for initial treatment of agricultural raw materials, the processes of mixing bulk masses have been widely applied. The intensification of these processes is possible when using vibratory machines [1]. Such machines are characterized by high intensity of processing various dispersed systems [2].

Agitation occurs in almost any process that employs vibration, but high-quality mixing is performed only in special units with targeted vibration [3, 4].

Application of vibratory machines for the agitation of bulk materials makes it possible to increase performance efficiency of the machine, reduce its energy consumption, and

improve the quality of the obtained mixture [5, 6]. An intensive oscillatory motion of controlling elements of vibratory machine contributes to the creation of circulating transportation of a mixture in the processing zone and ensures destruction of coagulating structures of the treated material.

## 2. Literature review and problem statement

A key operation in the mechanical treatment of loose raw materials is the process of mixing various highly-dispersed materials [7]. In most cases, this process is implemented following the creation of shear deformations of layers of a material during rotation of various blades and augers [8, 9]. At the same time, in order to ensure uniform distribution of components in the mixture, the particles of the dispersed mass must be set in motion along such trajectories that would provide the highest probability of their crossing the entire volume of the mixture [10, 11]. However, complexity of this phenomenon is predetermined by the existence of inertia forces, as well as forces of dry friction (friction of particles against each other). The negative factors also include the forces of dry external friction (friction of particles of the material against the container, blade or other working bodies

of the mixer), which are typically by an order of magnitude lower than the forces of dry internal friction [12, 13]. In addition, during mixing it is necessary to overcome the forces of gravity trying to bring particles of the material down, which leads to stratification.

In order to characterize a vibration field during mixing, to determine the state of the loose medium, overload coefficient  $k$  is used, which is also termed in the literature [14] as a coefficient of vibration mode, or a dynamic factor.

It was established experimentally that at the value of coefficient of vibration mode  $k = 2,5 - 3$  the conditions are created when total energy consumption for the drive of such a mixer is minimal, and it corresponds to the mode of continuous tossing the particles of the treated materials.

Under given parameters, it is expedient to employ a combined action of the vibration field and the rotating motion of the machine's working body. Under such conditions, it is possible to reach a value of heterogeneity of the mixture within 3 % at the process duration of 80–120 s.

The modern development of vibratory equipment is characterized by the wide use of progressive technologies based on the development and implementation of integrated systems of monitoring and control over quality parameters of technological impact. However, the functionality of such systems are typically not utilized in full because they are adapted to specific design features of various technological vibratory machines, which decreases efficiency of their application.

Therefore, development of autonomous systems to monitor and control basic characteristics of the vibratory equipment with a complex trajectory of motion is an important applied task: solving it is of great scientific and practical significance.

---

### 3. The aim and objectives of the study

---

The study conducted was aimed at designing an autonomous system of control over mode parameters of a vibratory mixer of loose materials, which would make it possible to obtain a highly homogeneous mixture at minimal energy consumption for its preparation.

To achieve the set aim, the following tasks must be solved:

- to analyze peculiarities of the behavior of loose raw materials under condition of vibration impact;
- to develop a structural scheme and practical implementation of an autonomous systems to control mode parameters of a vibratory machine for mixing loose raw materials. Such a system should functionally combine a unit for analysis of amplitude-frequency characteristics of the vibratory machine with the unit of system control over its drive mechanism;
- to establish effective mode parameters for the process of preparing a multi-component premix in the vibratory machine under condition of using the designed control system.

---

## 4. Materials and methods to study influence of operational parameters of the designed vibratory machines on the efficiency of the course of mixing process

---

### 4. 1. Examined materials and equipment used in the experiment

We selected the vitamin-mineral premix for poultry "DOLFOS D" to estimate the process of mixing in vibratory machines.

Composition of this premix consists of calcium carbonate, sodium chloride, calcium carbonate magnesium, dry fodder yeast, monocalcite phosphate, magnesium oxide, glycerol.

Vitamins: E 672, A 500000 MO, E 671, D<sub>3</sub> 100000 MO, E 675 mg, B1 45 mg, Pantonate acid 260 mg, Folic acid 5 mg, Choline 1000 mg. Microelements: E1 Iron (iron(II) sulfate), monohydrate 700 mg, E2 Iodine (potassium iodate) 12 mg, Cobalt (cobalt(II) hydroxycarbonate monohydrate) 10 mg, E4 Copper (copper sulphate, pentahydrate) 100 mg, E5 Manganese (oxide of manganese(II)) 800 mg, E6 Zinc (zinc oxide) 720 mg, E6 Zinc (zinc sulfate monohydrate) 180 mg, E8 Selenium (sodium(IV) selenite) 5 mg. Amino acids: sulfate L – lysine and by-products of fermentation 17.9 g, DL – Methionine + Cystine, technically pure, 6.4 g, calcium salt of methionine hydroxy analogue 4.5 g. Enzymes: 4a 12 6 – phytase (EC 3.1.3.26) 20 800 PPU. Antioxidants: E 324 Ethoxyquin 533.3 mg, E 321 VNT 588 mg, E 310 Propyl gallate 100 mg. Preservatives: E 330, Citric acid 1,000 mg.

We used the wireless tachometer UNI-T UT372 to register rotation frequency of the drive shaft. Controlling and changing rotation frequency of electric motor shaft was performed using the autotransformer AOSN-20-220-75, designed to operate under alternating current. In order to determine energy characteristics of the examined machine, we used the electronic wattmeter EMF-1, designed to measure power consumption in a 220 V grid, 16 A (maximum), connected to the household power outlet.

Amplitude-frequency response makes it possible to evaluate technological capacity of the designed vibrocentrifugal machine, to select required operational modes for the work of the machine under certain conditions. To establish the amplitude-frequency characteristics, we designed an accelerometer recorder of oscillation spectrum of the controlling element of vibratory machine.

When building this dependence, we take the value of oscillation amplitude for different modes of operation of the machine at certain points of the mixing chamber and drive shaft of the machine. Frequency response components are determined for the following cases: the absence of load, when using a working material. Energy characteristic can be determined for similar modes, in this case, the magnitude of drive power is based on data from electrical appliances of remote control unit.

Basic components of the designed recorder of amplitude-frequency characteristics is the microcontroller ATmega8, accelerometer LIS302DL, microSD memory card 2Gb, formatted in FAT32 file system, and a switch (Fig. 1, 2). For the operation of the device we created a programming interface based on the Windows operating system.

The switch, which is located on the front panel of the device, enables data recording mode into in a memory unit powered by an autonomous power source. To read data, a wired connection to the USB port of a computer is required with the enabled mode of data readout, which is turned on by clicking a virtual button "LEAD FLASH." Using the corresponding virtual buttons, we select the measured magnitude and spatial coordinates of X, Y, Z charts. To directly (online) enter information to a computer through the USB interface, it is necessary to put the switch into appropriate position and start clicking virtual buttons "LEAD LIS302DL", "START".

The principle of operation of the designed recorder is as follows. The recorder's sensor is connected to a vibratory machine followed by the switching of the electric motor. The

result of an oscillating motion of the vibratory machine is the activation of a built-in accelerometer, which starts recording amplitude-frequency characteristics to a memory flashcard. When the machine stops, the obtained data on frequency response, using the software and an adaptive cord, are interpreted in the form of graphic dependences and digital data matrix.

The developed hardware and software make it possible to analyze the vibration displacement, vibratory speed, vibratory acceleration and the intensity of oscillations under operating mode of the vibratory machine with a complex trajectory of motion of controlling elements.

In order to implement the process of preparation of highly-homogeneous loose substances, we designed and fabricated experimental model of the vibrocentrifugal mixer (Fig. 3) [15, 16]. The proposed design implements the idea of a combined interaction of vibratory and rotary motion of the controlling element utilizing the possibility of mixing in the pseudo-liquefied state of the treated medium.

The principle of operation of given structure is as follows. Upon loading the required amount of raw materials through a branch pipe into a cylindrical container for the preparation of one batch of product, the electric motor and the vibration drive are enabled, which results in the flat oscillation of the stringed platform. The torque from the electric motor, via an elastic coupling, a drive shaft and a gear, sets the crown in motion, as well as, accordingly, the cylindrical container with the spiral intensifier. Upon reaching the required homogeneity of the material, the motor and the vibration drive are turned off, followed by the unloading of raw material through a branch pipe.

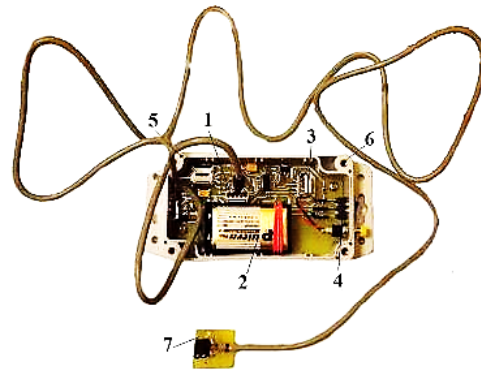

Fig. 2. Layout of the device: 1 – micro port for connecting the sensor of accelerometer; 2 – power battery; 3 – memory card; 4 – power button; 5 – adaptive micro port for data read-out; 6 – accelerometer housing; 7 – accelerometer

Such rotating and oscillating technological motion of the mixer’s controlling element makes it possible to significantly weaken the effect of adhesive forces, increase circulation motion of the treated material and, consequently, improve quality indicators of the resulting mixture. The result of the mechanical action of vibration and inertial and gravitational effects on the mixer’s controlling element and the bulk of the product is a significant intensification of the mixing process.

Structural model of control and analysis of operating parameters of the vibrocentrifugal mixer of loose materials is shown in Fig. 4.

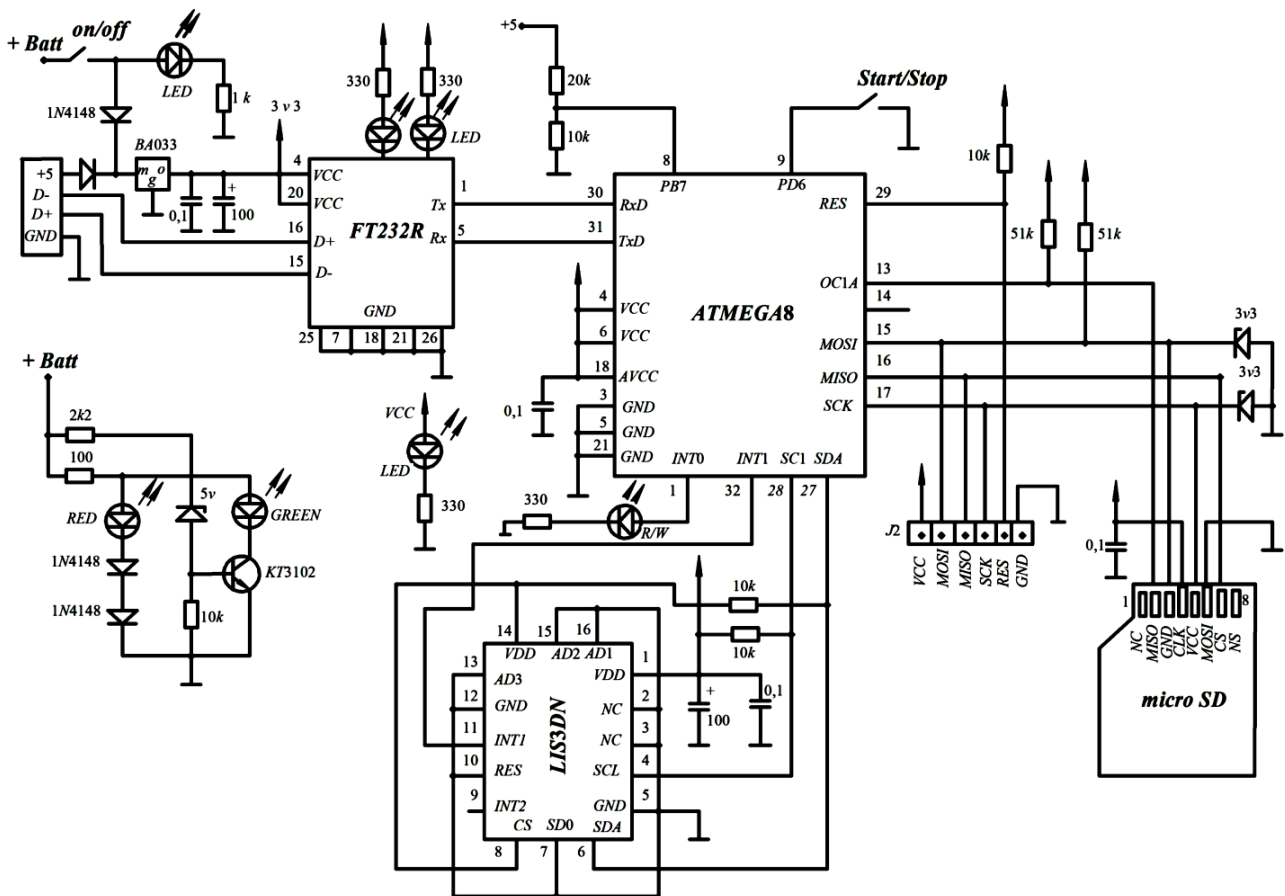

Fig. 1. Hardware-electronic circuit of the designed accelerometric complex

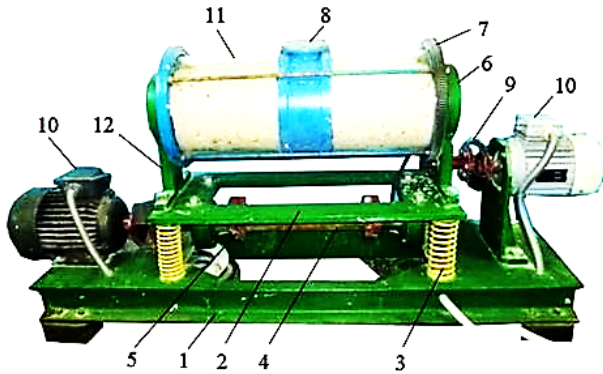

Fig. 3. Layout of the vibrocentrifugal mixer:

- 1 – bed; 2 – oscillatory platform; 3 – elastic elements;
- 4 – drive shaft; 5 – unbalanced masses; 6 – bearing units;
- 7 – toothed crown; 8 – loading neck; 9 – elastic coupling;
- 10 – electric motor; 11 – mixing chamber; 12 – racks

Experimental model of the mixer consists of drive platform 1 arranged on elastic elements 2. Platform 1, with racks 3, 4, and bearing units 5, 6, holds mixing container 7, which has loading neck 8 for loading and unloading the loose raw materials. Crown 9 is rigidly fixed on the end-side of this container, which is in contact with gear 10, which is mounted onto the drive shaft of electric motor 11. Controlled unbalanced vibration drive 12 is rigidly fixed to the bottom of drive platform 1, and it is connected to control unit 13. One of the inputs of control unit 13 is connected to the output of comparator 17, the other two inputs are connected, respectively, to accelerometric analyzer 19 and device 20 for the registration of angular velocity of the drive shaft of vibration drive. The structural circuit of control unit also includes three outputs, which in turn are connected to unbalanced vibration drive 12, one of the inputs to the block of synthesis and establishment of operational parameters 16, and the input of phase shift analyzer 14.

The second input of block of synthesis and establishment of operational parameters 16 is connected to one of the outputs of control unit of the drive of mixing chamber 18, other outputs of this unit are, accordingly, connected to electric motor 11 and phase shift analyzer 14.

To estimate and adjust rotation speed of the mixing chamber, block 16 has two inputs. One is for receiving information from device 21, one is for information from compactor 15. In turn, compactor 15 is connected to the input of phase shift analyzer 14 and the input of block of synthesis and establishment of operational parameters 16. To estimate the pseudo-liquefied state of the treated material, analyzer 14 is connected to accelerometric device 22.

To ensure efficient mixing of loose materials at minimal specific energy consumption, it is necessary to provide optimal parameters of the vibration impact, implemented in mixing container 7. At given parameters, the magnitude of non-uniformity of the starting mixture  $V_c(\%)$  approaches zero.

Turning on unbalanced vibration drive 12 and electric motor 11 creates a combined force and momentum non-equilibrium of eccentrically arranged masses. Oscillating and rotating motion of mixing container 7 is characterized by vibration acceleration  $a_d$ , angular velocity of the drive shaft  $\omega_s$  and angular rotation velocity of container  $\omega_c$ . As a result of translational displacement relative to the vertical and horizontal axes, the controlling element of the machine performs a movement along the elliptical trajectory.

It should be noted that the effect of vibrations makes it possible to significantly reduce the effort required by the particles of loose medium for their motion relative to each other.

A decrease in the acceleration of force field  $a \gg g$  leads to further reduction of effective coefficient of friction due to complete or partial separation of particles from each other and relative to the vibratory surface. Experimental data indicate that the effective friction coefficient may be reduced by 40–50 times.

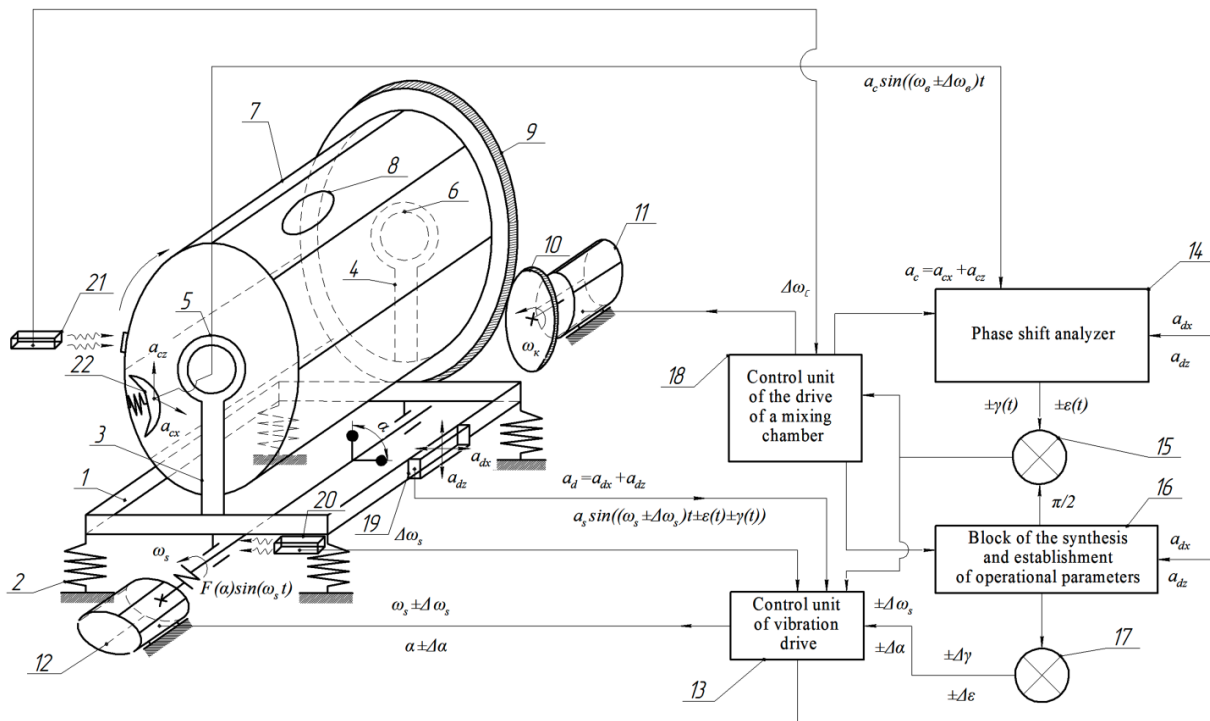

Fig. 4. Structural model of control and analysis of operational parameters of the vibratory mixer of loose materials



We can highlight vibration liquefaction, vibration segregation and vibration boiling among the main stages of processing loose material. Moreover, the most negative stage is vibration segregation or separation of material (when the forces pushing out the particles with lesser density become larger than the force of friction in the medium). It is worth noting that intensive agitation of a material is observed at the stage of vibration boiling.

A transition from vibration liquefaction to vibration boiling is characterized by a decrease in the effective viscosity by 2 orders of magnitude.

In this case, the process of vibration agitation depends not only on the physical and mechanical properties of the medium, but also on the design features of the vibratory machine. The rate of this process reaches its peak at maximum loosening of the medium layer and starts to decrease with a further increase in the parameters of vibration.

The transfer of energy from the source of vibration into the depth of loading mass occurs as a result of the motion of shock pulse in it, which fades as friction forces are overcome at inelastic deformations, also as a result of micro-cutting, crushing, and other factors. With increasing frequency, the energy of oscillations is localized in a thinner layer of interacting particles and does not have time to get inside a technological medium. In turn, an increase in the amplitude of oscillations at constant value of vibration acceleration contributes to the increase in the depth of penetration of shock pulses under conditions of a vibration field.

Such results substantiate that the process of oscillation propagation in a loading mass is the relaxation one whose course requires certain time. It is worth noting that a zone of vibration liquefaction in the technological loading of the vibratory machine is observed to the magnitude of coefficient  $k=2,4-2,5$ . Additionally, except for a quantitative change in the boundaries of a vibration liquefaction zone and a vibration boiling zone, no qualitative changes in the behavior of the technological medium in a confined vibratory space of the working chamber are observed. In addition, as the oscillation frequency increases, more pronounced are the forces of viscous friction, even though the magnitude is insignificant compared to the forces of dry friction, which is confirmed in studies.

Continuous contact between a technological load and a vibratory surface ensures the dissipation of energy in a medium, averaged over the period of oscillations.

Frequency mode of work of the vibratory machine determines, for the most part, a degree of dynamic influence on the elements of designs of the oscillatory system. It should be noted the most common are the resonance and the above-resonance modes.

The influence of resonance mode on oscillatory technological systems can be divided into internal and external. The external influence is caused by the freezing of a drive mechanism at resonance frequency when the engine begins to work under a mode of transformer. This leads to fast overheating of the engine and its breakdown. It should also be noted that the resonance mode of work of the vibratory machine leads to a sharp increase in the amplitude of oscillations. This phenomenon causes wear of anchor nodes of the drive shaft of vibratory exciter when passing the resonance. This transition is equivalent to the work of bearing assemblies for 100–120 hours under a preset mode.

Thus, despite the high dynamics of the resonance mode at minimal energy consumption, the indicated shortcomings limit its technological application.

The above-resonance technological mode is characterized by a significantly greater stability at working frequencies. Due to a more rigid suspension of the working container, the necessary requirements are satisfied in terms of the vibration protection of design of a vibratory machine. Under a given operational mode, the principle of the auto-balancing of an oscillatory system is implemented. This principle implies that at much larger frequencies than their own oscillation frequency, the unbalanced masses are prone to self-centering. That is, the center of masses tends to be located on the rotation axis. The result is significantly reduced unbalanced masses that are transmitted to the supports of the drive shaft. By analyzing the range between resonance frequency and the frequency of steady mode, it is possible to determine a stepwise increase in the amplitude of oscillations whose peaks decrease as it approaches steady mode.

In other words, the optimal operational parameters of the designed vibratory machine and minimal energy consumption for the implementation of the examined mixing process will be observed under above-resonance mode, that is, at constant value of the coefficient of dynamic mode of the mixing chamber within the range of 2.4–2.5.

The frequency of own oscillations of mixing container  $\omega_0 = f(m)$  depends on the mass of a technological loading, which in turn depends on the ratio between basic ingredients of the loose medium and the required volume of the finished product to be received.

Velocity  $\omega_s$  of unbalanced vibration drive 12 differs from own oscillation frequency of mixing chamber by  $\omega_0 = f(m)$  and from the oscillation frequency of the treated material by  $\omega_0 = f(m_1)$ . That is, there is a difference in the excitation of force pulses between the forced oscillation power of vibratory machine  $F(\alpha)\sin(\omega t)$ , forced oscillations of the treated material  $a\sin(\omega \pm \Delta\omega)t$  and forced oscillations  $a\sin((\omega \pm \Delta\omega)t \pm \varepsilon(t) \pm \gamma(t))$  of mixing chamber 7.

A characteristic of the components of vibration acceleration  $a_d$  of mixing container 7 and the angular speed of the drive shaft  $\omega_s$  are constantly supplied from accelerometric analyzer 19 and tachometer 20 to vibration drive control unit 13, to the block of synthesis and establishment of operational parameters 16 and to phase shift analyzer 14. In turn, control unit of the drive of mixing chamber 18 continuously sends a signal about speed of rotation of the controlling element of the machine to analyzer 14, which simultaneously monitors level of the pseudo-liquefied state of the treated material in the form  $a\sin(\omega \pm \Delta\omega)t$ .

In the process of operation, units 13 and 18 constantly transmit to phase shift analyzer 1 a signal (information) about real (actual) frequency of mixing power of the controlled unbalanced vibration drive 12. These units also register oscillation frequency of mixing container 7 and of the treated material. As a result, phase detector 14 determines phase shift  $\pm\varepsilon(t)$ ,  $\pm\gamma(t)$  between forced oscillations of container 7, cyclic forcing power of unbalanced vibration drive 12 and the treated material.

Different load mass has its own oscillation frequency  $\omega_0$ , which is characterized by angle  $\alpha(t)$ . An analysis of angle  $\alpha(t)$  makes it possible to determine the value and direction of correction  $\pm\Delta\omega$  of the frequency of cyclic forcing force  $\omega_s$  of vibration drive 12 and ensure permanent equality  $\omega_s \approx \omega_0$ . That is why information about the phase shift  $\varepsilon(t)$

from phase shift analyzer 14 enters comparator 15 where it is compared with block 16 of the synthesis and establishment of operational parameters, from the point of view of energy efficiency, angle  $\pi/2$ . The angle, equal to  $\pi/2$ , between forced oscillations of mixing chamber 7 and cyclic forcing force of controlled unbalanced vibration drive 12 will be observed under resonance mode of work of the vibratory mixer.

The dynamic state of controlled vibrosystem 15  $\pm\Delta\varepsilon$  in the form of difference  $\pi/2 - \varepsilon(t) - \gamma(t)$  to control unit of vibration drive 13 and control unit of the drive of mixing chamber 18.

Block of the synthesis and establishment of operational parameters 16, based on the magnitudes and their signs  $\pm\Delta\gamma$ ,  $\pm\Delta\varepsilon$  based on the classical laws of control, forms correction coefficients  $\pm\Delta\omega_c$ ,  $\pm\Delta\omega_s$  frequency of cyclic forcing force  $\omega_s$  of controlled vibration drive 12. The obtained value of forcing force  $\omega_s \pm \Delta\omega_s$  of unbalanced vibration drive 12 based on the signal is transmitted to phase analyzer 14, which under continuous mode determines  $\varepsilon(t)$ . The result of this functional interaction is the implementation of adaptation of work, constant over time, of the designed vibratory mixer to the above-resonance mode of operation, that is, optimization of work of the vibratory mixer in terms of energy efficiency.

Monitoring units 13, 14, 16, 18 ensure above-resonance mode of the vibratory machine when loading with raw materials changes.

The designed structure enables optimal working values  $\omega_0$  for the operating modes of the vibratory mixer. That is, it makes it possible to obtain the preset mixture heterogeneity  $V_c(\%)$  at minimal treatment time  $t(c)$ . It should also be noted that the optimization of vibration acceleration of mixing chamber 7 should be carried out in such a way so that the treated material is constantly in the maximally pseudo-liquefied state. To this end, block of the synthesis and establishment of operational parameters 16 automatically calculates value  $a_d$  for the required level of vibration acceleration of mixing chamber 1 at each separate above-resonance frequency  $\omega_0$  of oscillations of the components of the examined vibrosystem.

To ensure the required heterogeneity of the treated material, the compactor constantly receives corrected value of vibration acceleration  $a_d$  and of the actual level of vibration acceleration of the machine. As a result of comparison, we obtain magnitude  $\pm\Delta\alpha$  and the direction of change in the amplitude of cyclic forcing force of controlled vibration drive 12. A dynamic change in the main operational parameters of the designed vibratory machine, cyclic rotation frequency of the drive shaft of controlled unbalanced vibration drive 14, the angle of arrangement of unbalanced masses relative to each other, will make it possible to allow for the required optimal dynamic state of mixing chamber 7.

The benefit of a given design is the use of energy of the oscillated housing and the absence of an additional drive. It should be also noted that such a structural implementation of the machine makes it possible to create a continuous technological action of the mixing bodies to the treated medium.

#### 4.2. The essence of assessment indicators of operational and qualitative parameters of the examined process

Among those technological parameters of the vibratory machine that need to be considered when designing it, we can highlight special features in the implementation of parameters of a vibratory field and in the organization of the product treatment cycle.

Basic parameters of the vibratory field are frequency  $\omega$  and amplitude of oscillations  $A$ , vibration acceleration  $a$ , vibration velocity  $v$ , and vibration intensity  $I$ .

Vibration acceleration is one of the main parameters that determine the behavior of particles in the technological medium of the vibratory machine. When the magnitude of vibration acceleration  $a$  approaches the acceleration of free fall  $g$ , a loose medium acquires the properties of vibration liquefaction. Together with compaction, there occur fluidity and loosening at a significant decrease in the viscosity of loose medium, which allows us to characterize the latter by rheological parameters.

The reserves for increasing the intensity of vibration treatment exist in machines with a combined force action, which implies the combination of vibrating and rotating motion of the elements of technological system. The object of such a technological influence, along with a vibratory working container, can be a technological medium.

Total energy of the oscillatory system can be divided into kinetic, potential, and the work of inertia force. The kinetic energy includes in turn the energy of oscillatory and rotating masses of the drive. The potential energy includes the energy of elastic elements of the working body and elastic joints in the working medium. Among the components of work of inertia forces, it is worth noting the weight of inertial elements over the period of oscillations and the energy of dissipation. The latter is dissipated in the form of heat inside the mass of a technological load and into the environment as a result of viscous and dry friction. These components cannot be calculated by a simple summing as they constitute the forms that are mutually transformed one into one. Thus, the energy of rotating masses is converted into the energy of an oscillatory process of the working bodies, which leads to the emergence of circulating motion of technological load and is partially scattered to overcome the forces of friction.

In a general case, basic energy parameters of vibration include the work of forcing forces or moments, and internal resistance forces of the oscillatory system. The work of external forces is created by a vibratory exciter and is used to overcome resistance forces of the system and to enable the oscillatory motion of controlling elements of the vibratory technological machine with preset parameters.

Internal resistance forces of the oscillatory system are the forces of reactive and dissipative resistance.

In addition, part of the energy that is supplied from an external source is typically consumed in a variety of intermediate gears, connecting joints, in the motor itself and in other units of the vibratory machine. The consumption of energy in mechanical drives depends on the structural circuit of a vibratory machine and is determined from result of specialized kinematic estimations.

Energy consumption of the electric motor consists of consumption in the stator and in the rotor of electric machine. Energy in the stator is spent on remagnetization, on vortex current in the stator magnetic conductor, on heating the stator winding by current. In the rotor, energy is used for heating the coil and in the magnetic conductor. The latter is almost zero due to a low value of flow frequency in the electric circuit of the rotor. Energy cost of remagnetization and vortex flows in the magnetic conductor is constant for a given type of electric motor and does not depend on the load on the motor shaft. Energy consumption for heating the windings of the stator and the rotor depends on the magni-

tude of current, which is determined by useful capacity that is needed to drive the vibratory machine.

In order to determine quality indicators of the mixing process, we shall use the hourly method for mixture assessment based on statistical analysis, according to which, based on samples, we perform estimation for one random magnitude. For this purpose, we select one key component in the mixture, and all the other components are combined. The quality of mixing is assessed by the degree of spread of the key component in the mass of another conditional component. Thus, in a two-component mixture, random magnitude  $M$  is the content of the key component in microvolumes. Random discrete magnitude  $M$  can be fully characterized if there is a law of distribution, mathematical expectation  $X$ , variance  $D$ , or root-mean-square deviation  $S$ . Most researchers accept as the base of criterion for the assessment of mixture quality the root-mean-square deviation in the content of key component in the samples, selected from the resulting mixture:

$$S = \sqrt{\frac{\sum_{i=1}^n (M_i - \bar{m})^2}{n-1}}, \quad (1)$$

where  $M_i$  is the content of key component in the  $i$ -th sample;  $\bar{m}$  is the arithmetic mean of the content of key component in all samples;  $n$  is the total number of samples.

At a large number of samples, magnitude  $\bar{m}$ , according to probabilistic forecasting, is equal to mathematical expectation  $X$  of random magnitude  $M$ . The root-mean-square deviation depends on magnitude  $\bar{m}$  and has its dimensionality. The samples are selected with a sample-taker in chess order from four depths of the container. Minimum mass of the sample is calculated from formula

$$G_M = \frac{10^4 \pi d^3 \rho}{c_0 + 1,5c_0} \approx \frac{1,26 \cdot 10^4 d^3 \rho}{c_0}, \quad (2)$$

where  $d$  is the diameter of particles in the mixture, cm;  $\rho$  is the bulk density of particles in the mixture,  $\text{g}\cdot\text{cm}^{-3}$ ;  $c_0$  is the value of a given concentration of the key component.

**5. Results of examining operational parameters of the vibratory machine and the assessment of mixing process**

In order to establish operational parameters of the designed vibratory centrifugal mixer, we performed assessment of the kinematic and speed characteristics of its controlling element.

The amplitude of oscillations of the mixing chamber in Fig. 5 is divided into three characteristic regions: below-resonance at  $\omega=0-31 \text{ rad}\cdot\text{s}^{-1}$ , resonance at  $\omega=36-57 \text{ rad}\cdot\text{s}^{-1}$ , and above-resonance at  $\omega=67-118 \text{ rad}\cdot\text{s}^{-1}$ , where we observed stabilization of oscillation amplitude.

Maximum values of oscillation amplitude under below-resonance mode independent on the degree of load of raw materials are  $A=3 \text{ mm}$ . In contrast, under resonance mode, the values of oscillation amplitude are: without a load  $A=5.8 \text{ mm}$ ; at  $r=1/2$ ,  $A=5.3 \text{ mm}$ ; at  $r=3/4$ ,  $A=5 \text{ mm}$ . Under above-resonance mode, the value of amplitude is in the range  $A=2-2,2 \text{ mm}$ .

An analysis of the above data allowed us to conclude that an increase in the degree of load with raw materials leads to a decrease in the oscillation amplitude; this is especially noticeable over the resonance period when this phenomenon occurs due to a significant growth of the dissipative forces in the treated material, and a shift in the oscillation amplitude of the container is implemented in the direction of increasing angular velocity of the drive shaft of the vibratory exciter.

In this case, Fig. 5 shows that the values of vibration speed and vibration acceleration at angular frequency of the drive shaft  $\omega=118 \text{ rad}\cdot\text{s}^{-1}$  are in the range of  $v=0.25-0.27 \text{ m}\cdot\text{s}^{-1}$ ,  $a=28-30 \text{ m}\cdot\text{s}^{-2}$  and do not yield a significant range of magnitudes. The maximum values of the intensity of oscillations  $I=7-10 \text{ m}^2\cdot\text{s}^{-3}$  of the controlling element of a vibratory machine are observed at  $\omega=118 \text{ rad}\cdot\text{s}^{-1}$ . This treatment mode is characterized by a considerable dynamic state of the controlling element as a consequence of active circulation of the loose mass.

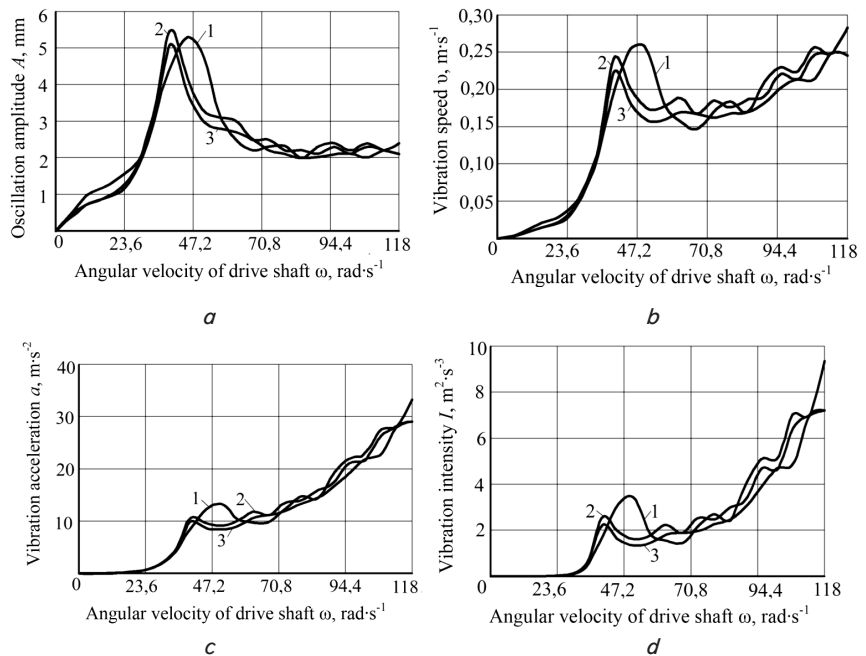

Fig. 5. Amplitude-frequency and speed characteristics of the machine depending on angular velocity of the drive shaft  $\omega$  and coefficient of load with raw materials  $r$ : a – oscillation amplitude; b – vibration speed; c – vibration acceleration; d – vibration intensity; 1 – without a technological filler; 2 – at  $r=1/2$ ; 3 – at  $r=3/4$

In order to estimate energy consumption of the examined vibratory machine, we performed a series of experimental studies depending on a change in the degree of loading and vibration factor  $k$ .

An analysis of Fig. 6 revealed that the growth of vibration factor of the controlling element of the machine from 1.2 to 5.2 is accompanied by rising energy consumption of the vibratory exciter from  $N_s=0.4 \text{ kW}\cdot\text{h}$  to  $N_s=1.0 \text{ kW}\cdot\text{h}$  and by reduced energy consumption of the drive of the mixing chamber from  $N_c=0.8 \text{ kW}\cdot\text{h}$  to  $N_c=0.4 \text{ kW}\cdot\text{h}$ . This leads to the emergence of a minimum in the total energy costs for the implementation of active treatment of raw materials

under condition of continuous tossing of particles of a loose material.

Based on the above data, we can conclude that a change in the vibration factor is one of the dominant factors in the total energy consumption of the devised vibratory machine in the course of the mixing process.

This reduction in energy consumption for the drive of a mixing chamber at an increase in the coefficient of vibration mode is explained by a decrease in the effective coefficients of internal and external friction under the action of a vibration field.

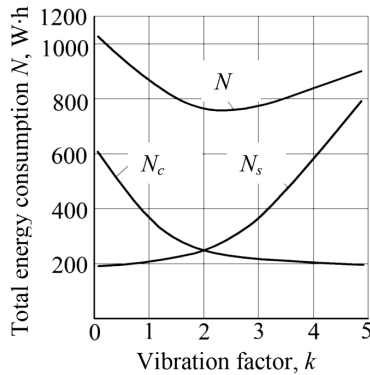

Fig. 6. Dependence of energy consumption of vibratory mixer on vibration factor  $k=a^2g^{-1}$  (at  $n_c=70\text{ s}^{-1}$ ,  $n_s=1,100\text{ s}^{-1}$ , load degree  $\frac{3}{4}$ );  $N_\Sigma=N_s+N_c$  is the total energy consumption

An analysis (Fig. 7) revealed that energy consumption of the drive of a mixing chamber  $N_c$  at  $n_c$  to  $70\text{ s}^{-1}$  and at an increase in value  $k$  from 1.2 to 5.2 grow by 50 W·h.

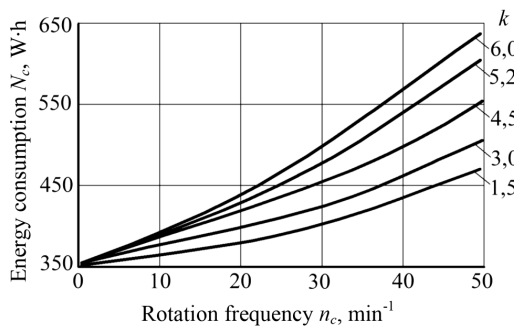

Fig. 7. Dependence of mixing chamber's drive energy consumption on rotation frequency of the container  $n_c$  and on a change in vibration mode factor  $k$

Fig. 8, 9 show a series of experimental curves for a change in the total energy consumption and overall oscillation amplitude at a change in the magnitude of forcing force and coefficient of loading with the treated material.

The data obtained indicate an almost proportional growth in the oscillation amplitude of the machine's controlling element and in power consumption. For example, without loading the treated material: at  $k=1.5$ ,  $N_\Sigma$  is 0.9 kW·h,  $A=1.5\text{ mm}$ ; at  $k=4.5$ ,  $N_\Sigma=1.0\text{ kW}\cdot\text{h}$ ,  $A=2.5\text{ mm}$ ; at  $k=1.5$ ,  $N_\Sigma=0.9\text{ kW}\cdot\text{h}$ ,  $A=1.5\text{ mm}$ ; at  $k=5.2$ ,  $N_\Sigma=1.1\text{ kW}\cdot\text{h}$ ,  $A=2.8\text{ mm}$ .

Following an increase in the degree of loading the mixing chamber, oscillation amplitude of the container is reduced by 1.5 times, while overall energy consumption grows by 1.6 times.

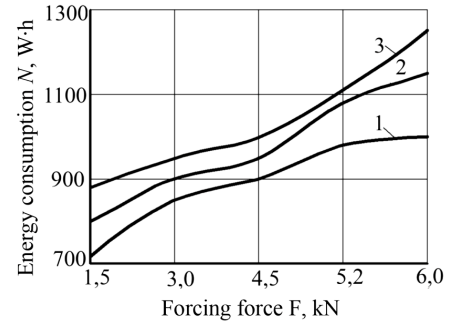

Fig. 8. Dependence of the vibratory machine's energy consumption on the magnitude of forcing force  $F$  and coefficient of loading with the treated raw materials  $r$ : 1 – at  $r=\frac{3}{4}$ ; 2 – at  $r=\frac{1}{2}$ ; 3 – without a technological filler

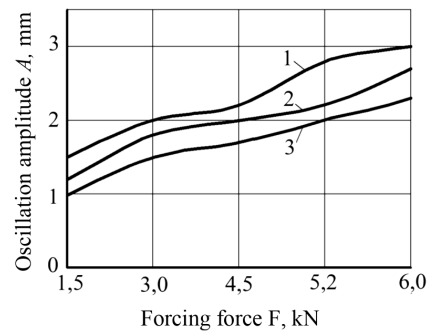

Fig. 9. Dependence of oscillation amplitude on forcing force  $F$  and coefficient of loading with the treated raw materials  $r$ : 1 – at  $r=\frac{3}{4}$ ; 2 – at  $r=\frac{1}{2}$ ; 3 – without a technological filler

Fig. 10 also shows that a growth of the angular velocity of the mixer's drive shaft is accompanied by almost quadratic growth in total energy consumption  $N_\Sigma$ ; at  $r=\frac{3}{4}$  and at  $\omega=20\text{ rad}\cdot\text{s}^{-1}$ ,  $N_\Sigma=0.2\text{ kW}\cdot\text{h}$ , whereas at  $\omega=118\text{ rad}\cdot\text{s}^{-1}$ ,  $N_\Sigma=1.2\text{ kW}\cdot\text{h}$ .

It is also worth noting the increase in total energy consumption depending on the coefficient of loading with the treated raw materials; thus, at angular velocity  $\omega=118\text{ rad}\cdot\text{s}^{-1}$ , total energy consumption of the machine  $N_\Sigma$  will equal to: without a load –  $N_\Sigma=1,000\text{ kW}\cdot\text{h}$ , at  $r=\frac{1}{2}$ ,  $N_\Sigma=1.1\text{ kW}\cdot\text{h}$ ; at  $r=\frac{3}{4}$ ,  $N_\Sigma=1.25\text{ kW}\cdot\text{h}$ .

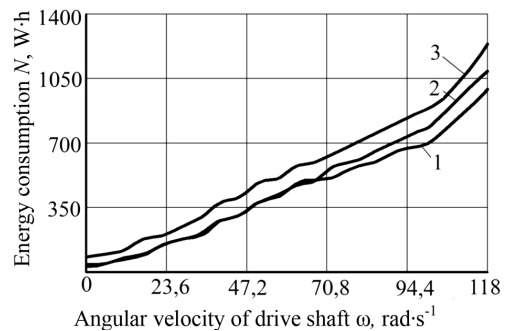

Fig. 10. Dependence of total energy consumption of the examined vibratory machine on angular velocity of the drive shaft  $\omega$  and coefficient of loading with the treated raw materials  $r$ : 1 – at  $r=\frac{3}{4}$ ; 2 – at  $r=\frac{1}{2}$ ; 3 – without a technological filler

During experimental study, in order to assess quality indicators of the mixing process, we used material with a



humidity of 7–10 %. The treated material was divided into two groups depending on the physical-mechanical characteristics. The first group included rapeseed and millet with dimensions of 1.5–2.0 mm. The second group included a highly-dispersed material in the form of powders with a particle size of 20–50  $\mu\text{m}$ .

An analysis of Fig. 11 revealed a decrease in the coefficient of variation of the resulting mixture under condition of rotating motion of the container  $V_c=10\%$  at  $t=150\text{ s}$ , whereas under condition of vibration exposure  $V_c=8\%$  at  $t=60\text{ s}$ , and during vibrating centrifugal treatment  $V_c=5\%$  at  $t=50\text{ s}$ .

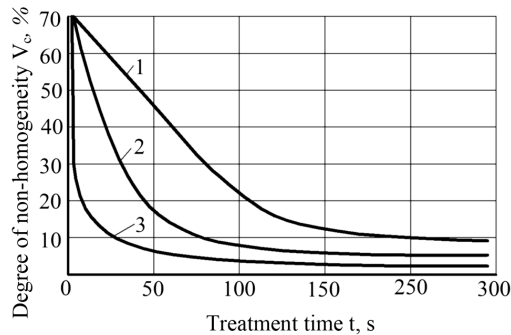

Fig. 11. Dependence of the degree of heterogeneity of the mixture on treatment time  $t$  and the type of technological impact: 1 – centrifugal motion of the container; 2 – oscillatory motion of the container; 3 – vibratory centrifugal motion

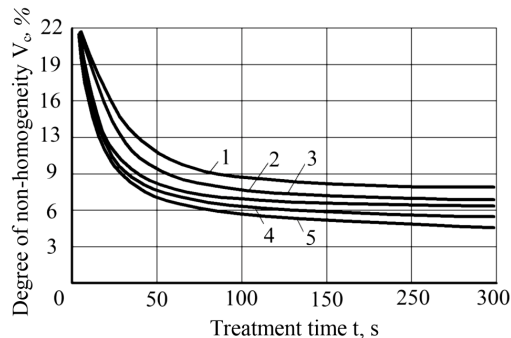

Fig. 12. Dependence of the degree of heterogeneity of the mixture  $V_c$  on treatment time  $t$  and vibration factor (vibratory centrifugal treatment technique,  $n_c=70\text{ s}^{-1}$ ): 1 –  $k=1.5$ ; 2 –  $k=3$ ; 3 –  $k=4.5$ ; 4 –  $k=5.2$ ; 5 –  $k=6$

An analysis of Fig. 12 allowed us to establish that the main phase of mixing occurs over the first period of treatment whose duration  $t=50\text{ s}$ , and variation coefficient  $V_c$  depends on vibration factor  $k$ . Thus, at  $\omega=118\text{ rad}\cdot\text{s}^{-1}$ , rotation velocity of the mixing chamber  $n_c=70\text{ s}^{-1}$  and treatment time 60 s,  $V_c$  will be equal at  $k=1.5$  to 9 %, whereas at  $k=6$ ,  $V_c=5\%$ .

During second period, the degree of non-homogeneity is almost unchanged characterizing the onset of dynamic equilibrium, after which further process of mixing is ineffective. The obtained dependences allowed us to establish that the non-homogeneity of a mixture decreases with increasing duration of the treatment of mixture under all examined modes of operation.

It is also worth noting that an increase in the time of treatment the magnitude of non-homogeneity coefficient alternately decreases or increases, approaching a certain boundary value. Such a performance of the mixture is relat-

ed to the existence of a convective mechanism of the process that causes oscillations of the plane of contact surface of mixing phases from maximum to minimum.

### 6. Discussion of results of the study of operational parameters of the vibratory machine

The designed control system allowed us to establish effective operational parameters of the vibratory machine for preparing a premix. We highlight the following: angular velocity of the drive shaft  $\omega=110\text{--}120\text{ rad}\cdot\text{s}^{-1}$ ; oscillation amplitude  $A=2.0\text{--}2.2\text{ mm}$ ; vibration velocity  $v=0.25\text{--}0.28\text{ m/s}$ ; vibration acceleration within a range of  $a=28\text{--}30\text{ m/s}^2$ ; intensity of oscillations  $I=6\text{--}8\text{ m}^2/\text{s}^3$ . At given parameters, homogeneity of the resulting mixture over 25–40 seconds is 96–98 %; energy consumption of the vibratory mixer is:  $N=1,000\text{ W}\cdot\text{h}$ , at  $\frac{1}{2}$  load;  $N=1,100\text{ W}\cdot\text{h}$  at  $\frac{3}{4}$  load;  $N=1,250\text{ W}\cdot\text{h}$  when fully loaded.

It is worth noting that most of the known methods of control over technological parameters of vibratory machines, in order to reduce specific energy consumption on the implementation of mixing process, imply manual adjustment of machine by changing voltage or its frequency in electric drives. Additionally, to change amplitude-frequency characteristics of the vibratory system, the arrangement of unbalanced masses is manually changed. Moreover, the above control methods are labor-intensive and complicate the process of adjusting operational parameters of vibratory machines depending on the type of the treated material or the degree of its load into a mixing container.

The designed system improves control systems based on adapted vibration drive that may enable a change in the arrangement of its unbalanced masses during operation of the vibratory machine. However, the shortcoming of these systems is the assessment of amplitude-frequency characteristics of the machine only.

In contrast, in the proposed system, the monitoring unit runs a comprehensive analysis of kinematic and speed characteristics of both the machine and the dynamic state of the treated material.

The proposed control system is autonomous and is based on the principle of ensuring maximally active dynamic state of the treated loose material. This type of treatment is based on the prerequisite of creating effective circulating flows that are tracked in the pseudo-liquefied state of a material, which in turn ensures the above-resonance operating mode of the vibratory machine.

The structure of the given control system includes three main units. The first unit estimates basic kinematic and speed characteristics of the vibratory machine and a loose mixture in the course of its treatment. The second unit analyzes input data and their discrepancy, establishing corrected values for the operational modes of drive mechanism of the vibratory machine. The third unit enables mechanical adjustment of the drive system ensuring the required operational parameters for work of the vibratory machine.

The main shortcoming of the designed control system is, in our opinion, an indirect empirical assessment of qualitative characteristics of the prepared mixture. In other words, further development of the given control systems is the introduction of an integrated unit for the assessment of mixture's homogeneity in the process of its preparation. A promising direction of such a modernization is the use

of photo-analytical devices for the evaluation of material's homogeneity at each stage of its treatment.

---

## 7. Conclusions

---

1. It was established that a promising way to improve efficiency of the processes of mixing loose materials is the application of vibratory machines. Vibration impact leads to increasing porosity of dispersed medium and decreases its density. This effect triggers a complex circulating motion of loose raw materials in the mixing chamber and, consequently, uniform distribution of particles of the material throughout the entire volume of the mixture.

2. We designed an autonomous system to control operational parameters of the vibratory mixer for loose raw materials. This system enables active analysis and correction of the basic kinematic and speed characteristics of the vibratory machine in the course of its work, ensures highly-dynamic state of treatment of loose raw materials regardless of its physical and mechanical properties and the volume of filling a mixing chamber of the machine.

3. By using the designed control system, we established effective operational parameters for the vibratory machine intended to prepare a premix, which ensure minimal energy consumption for the preparation of a highly-homogeneous mixture.

---

## References

1. Blekhman, I. I. Dvizhenie chastitsy v koleblyushchey sredy pri nalichki soprotivleniya tipa suhogo treniya [Text] / I. I. Blekhman, V. V. Gortinskiy, S. E. Ptushkina // *Mekhanika v mashinostroyeni*. – 1963. – Issue 4. – P. 31–41.
2. Honcharevych, I. F. Teoriya vibratsiynoi tekhniki ta tekhnolohiy [Text] / I. F. Honcharevych, K. V. Frolov. – Moscow: Nauka, 1981. – 320 p.
3. Mizonov, V. Influence of crosswise non-homogeneity of particulate flow on residence time distribution in a continuous mixer [Text] / V. Mizonov, H. Berthiaux, C. Gatumel, E. Barantseva, Y. Khokhlova // *Powder Technology*. – 2009. – Vol. 190, Issue 1-2. – P. 6–9. doi: 10.1016/j.powtec.2008.04.052
4. Roseman, B. Mixing of solids [Text] / B. Roseman // *The industrial Chemist*. – 1973. – Issue 10. – P. 84–90.
5. Gyenis, J. Determination and randomness in mixing of particulate solids [Text] / J. Gyenis, F. Kátai // *Chemical Engineering Science*. – 1990. – Vol. 45, Issue 9. – P. 2843–2855. doi: 10.1016/0009-2509(90)80177-g
6. Potanin, A. A. On models of granular material flow under dynamic conditions [Text] / A. A. Potanin // *Powder Technology*. – 1992. – Vol. 69, Issue 2. – P. 107–117. doi: 10.1016/0032-5910(92)85063-2
7. Mizonov, V. A Markov chain model of mixing kinetics for ternary mixture of dissimilar particulate solids [Text] / V. Mizonov, I. Balagurov, H. Berthiaux, C. Gatumel // *Particuology*. – 2017. – Vol. 31, Issue 80–86. doi: 10.1016/j.partic.2016.05.006
8. Manley, D. Mixing and premixes in biscuit manufacture [Text] / D. Manley, H. Clark // *Manley's Technology of Biscuits, Crackers and Cookies*. – 2011. – P. 410–426. doi: 10.1533/9780857093646.4.410
9. Regner, M. Effects of geometry and flow rate on secondary flow and the mixing process in static mixers – a numerical study [Text] / M. Regner, K. Östergren, C. Trägårdh // *Chemical Engineering Science*. – 2006. – Vol. 61, Issue 18. – P. 6133–6141. doi: 10.1016/j.ces.2006.05.044
10. Kippers, N. Vibration of Standard Pitched Blade Impellers in Baffled Mixing Vessels. Vol. 4 [Text] / N. Kippers, G. Holloway // *Fluid-Structure Interaction*. – 2009. – P. 379–387. doi: 10.1115/pvp2009-77718
11. Sheliang, W. Effect of vibration mixing on the performance of recycled concrete [Text] / W. Sheliang, Z. Shimin, Z. Mingming, L. Wei // *Applied Engineering, Materials and Mechanics*. – 2016. – P. 119–127. doi: 10.1142/9789813146587\_0019
12. Osorio, J. G. Continuous Powder Mixing [Text] / J. G. Osorio, A. U. Vanarase, R. J. Romañach, F. J. Muzzio // *Pharmaceutical Blending and Mixing*. – 2015. – P. 101–127. doi: 10.1002/9781118682692.ch6
13. Vance, J. Fundamentals of Machine Vibration and Classical Solutions [Text] / J. Vance, F. Zeidan, B. Murphy // *Machinery Vibration and Rotordynamics*. – 2010. – P. 1–34. doi: 10.1002/9780470903704.ch1
14. Palamarchuk, I. P. Vyznachennia amplitudno-chastotnykh ta enerhetychnykh parametriv vibratsiynoi susharky dlia sushinnia nasinnia harbuza [Text] / I. P. Palamarchuk, O. V. Tsurkan, V. P. Yanovych, O. O. Herasymov, B. M. Pentiuk, O. V. Zhehaliuk // *Vibratsiy v tekhnitsi ta tekhnolohiyakh*. – 2012. – Issue 3. – P. 121–125.
15. Kaletnik, H. M. Doslidzhennia ekspluatatsiynykh kharakterystyk vibrovidtsentrovoho zmishuvacha dlia pryhotuvannia premiksiv [Text] / H. M. Kaletnik, V. P. Yanovych // *Sil'ske hospodarstvo ta lisivnytstvo*. – 2017. – Issue 5. – P. 6–16.
16. Palamarchuk, I. P. Rozrobka vibrovidtsentrovoho zmishuvacha dlia vyrobnytstva sypkykh substansiy [Text] / I. P. Palamarchuk, V. P. Yanovych, Yu. O. Mykhalova // *Tekhnika, enerhetyka, transport APK*. – 2017. – Issue 1 (96). – P. 104–107.