

# VINNITSA NATIONAL AGRARIAN UNIVERSITY

Department of Electric Power Engineering, Electrical Engineering and Electromechanics



## CALCULATION OF ELECTRICAL CIRCUITS BY KIRCHHOFF'S RULES

by Associate Professor V. Hraniak



## FIRST KIRCHHOFF'S RULE

The algebraic sum of the currents in any circuit node is ZERO

in other words

The sum of the currents entering the node is equal to the sum of the currents leaving it

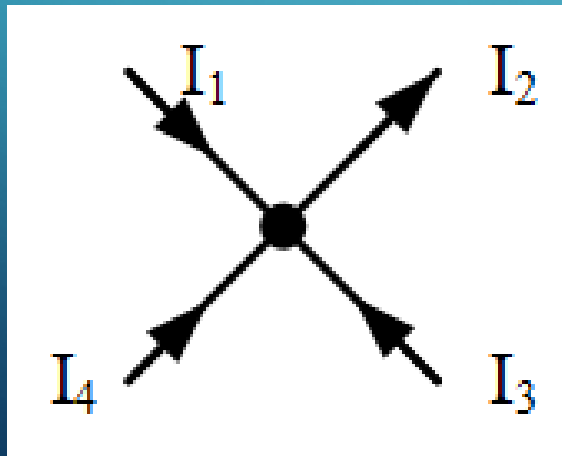

$$I_1 + I_3 + I_4 = I_2$$



## SECOND KIRCHHOFF'S RULE

The algebraic sum of EMF (electromotive force) in a closed loop is equal to the algebraic sum of the voltage drops on the resistances of this loop.

in other words

The sum of EMF taking into account the sign (if the direction of EMF coincides with the selected direction of the current, then "+", if it is opposite to it, then "-") is equal to the sum of products  $R \cdot I$ , taking into account the sign (if the direction of EMF coincides with the selected direction of current, then "+", if opposite to it, then "-")

# SECOND KIRCHHOFF'S RULE (EXAMPLE)

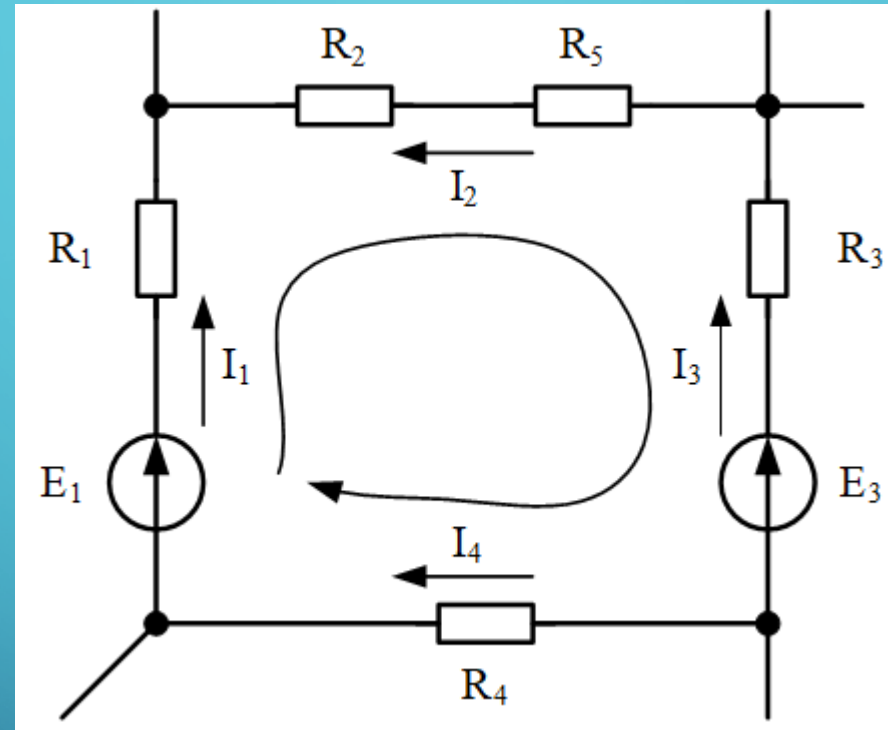

$$E_1 - E_3 = I_1 \cdot R_1 - I_2 \cdot R_2 - I_2 \cdot R_5 - I_3 \cdot R_3 + I_4 \cdot R_4$$

## PECULIARITIES OF COMPILING A SYSTEM OF EQUATIONS ACCORDING TO KIRCHHOFF'S RULES

1. The number of system equations is equal to the number of unknown currents.
2. According to first Kirchhoff's rule, the number of equations that is "1" less than the number of nodes in the circle is formed.
3. The rest of the equations are formed according to second Kirchhoff's rule for a system of independent loops formed in a circle.



## EXAMPLE

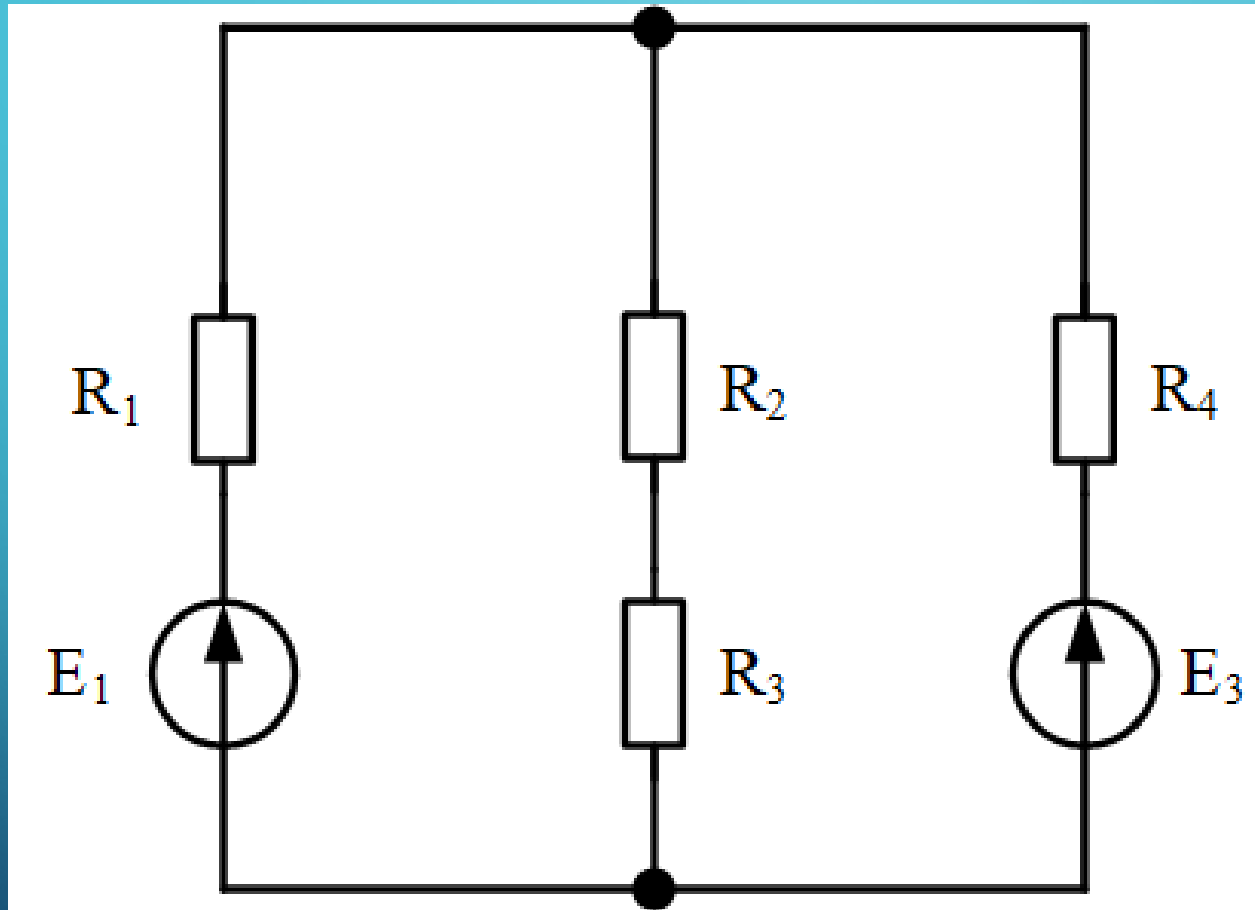

Condition:

$$E_1 = 60 \text{ V}$$

$$E_3 = 20 \text{ V}$$

$$R_1 = 15 \text{ Ohm}$$

$$R_2 = 10 \text{ Ohm}$$

$$R_3 = 20 \text{ Ohm}$$

$$R_4 = 10 \text{ Ohm}$$

# LET'S SET THE DIRECTIONS OF THE CURRENTS AND COMPLETE A SYSTEM OF INDEPENDENT CIRCUITS

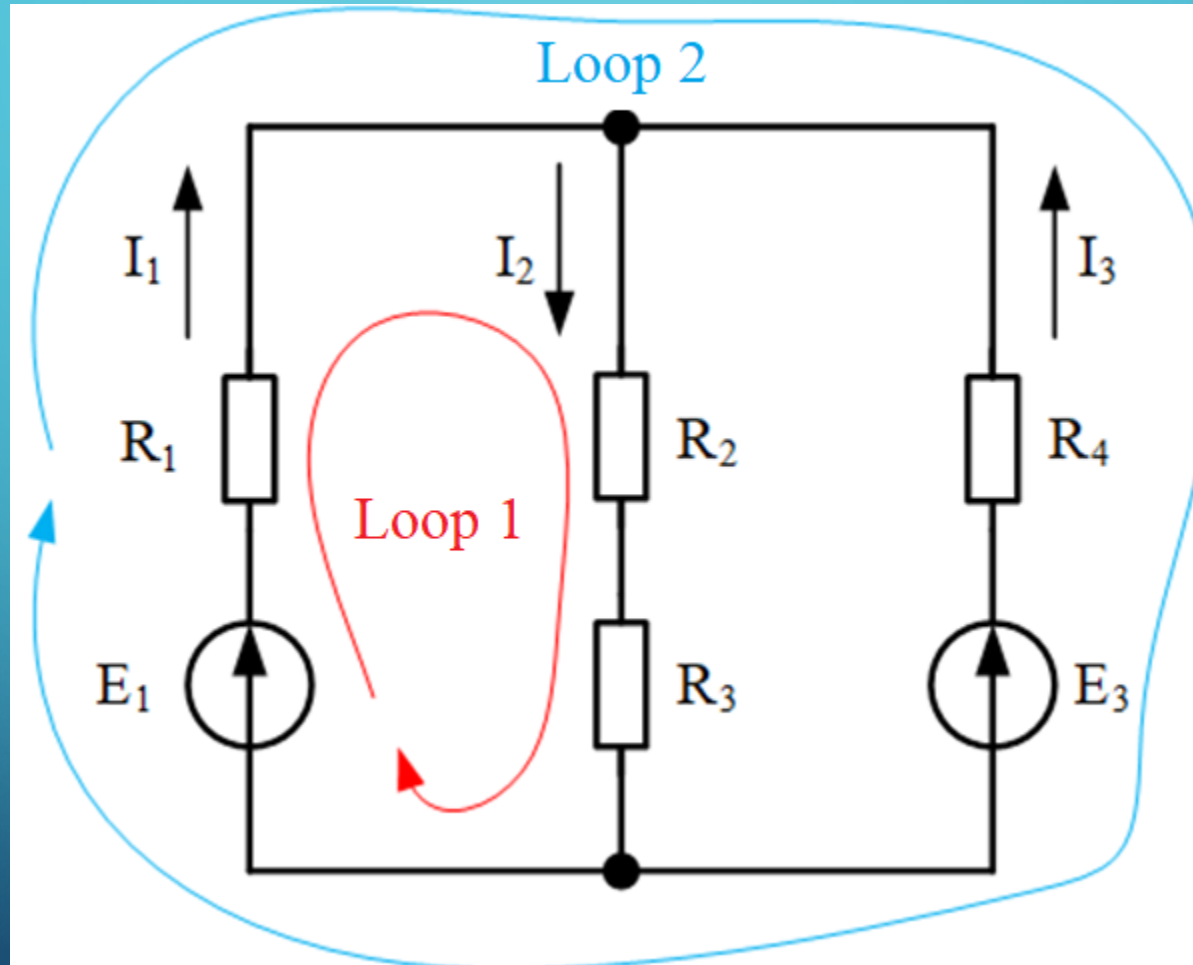

# COMPLETE THE SYSTEM OF EQUATION

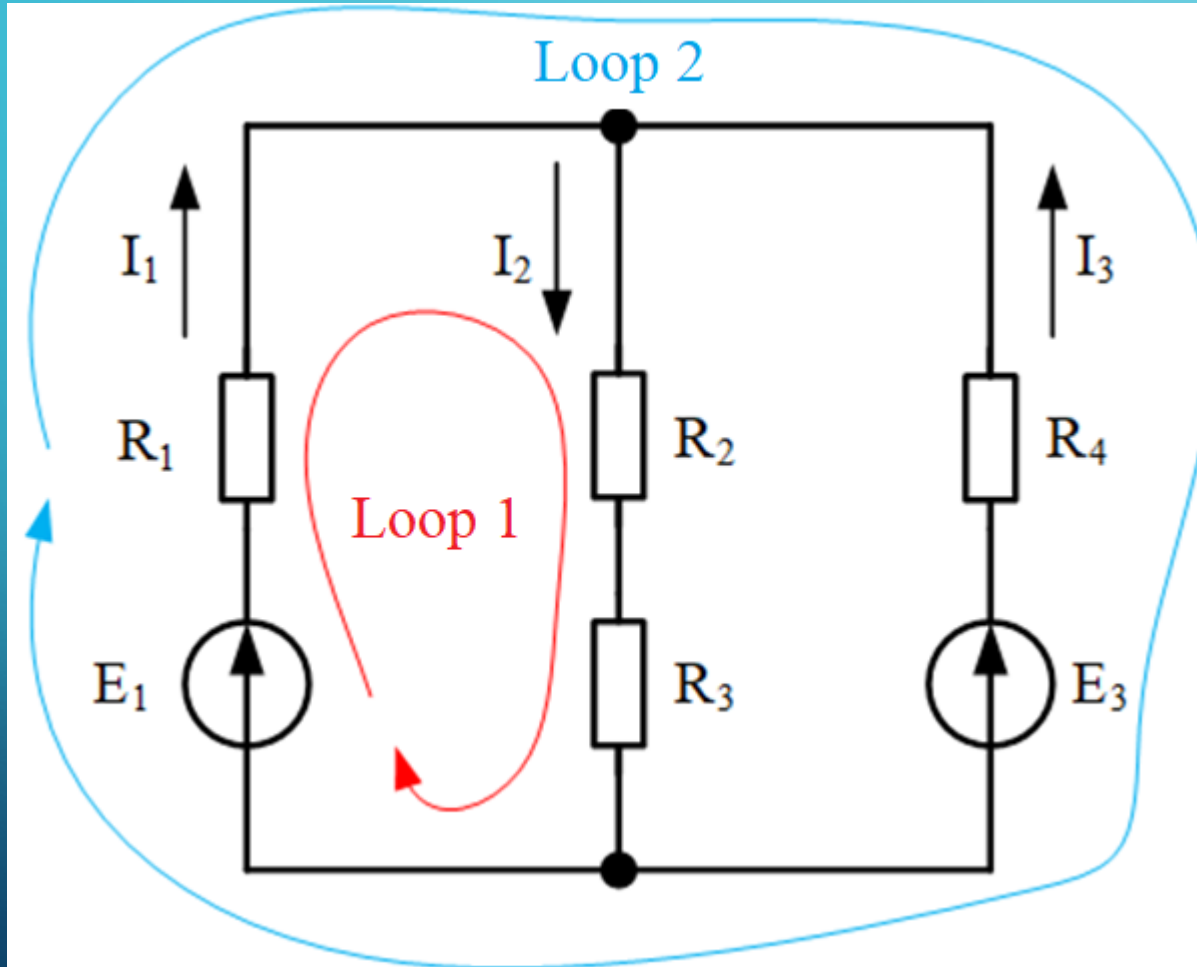

Equation 1

(1 rule, up node)

$$I_1 + I_3 = I_2$$

Equation 2

(2 rule, 1 loop)

$$E_1 = I_1 \cdot R_1 + I_2 \cdot (R_2 + R_3)$$

Equation 3

(2 rule, 2 loop)

$$E_1 - E_3 = I_1 \cdot R_1 - I_3 \cdot R_4$$



# CALCULATION OF THE SYSTEM OF EQUATION

$$\begin{cases} I_1 + I_3 = I_2, \\ E_1 = I_1 \cdot R_1 + I_2 \cdot (R_2 + R_3), \\ E_1 - E_3 = I_1 \cdot R_1 - I_3 \cdot R_4. \end{cases}$$

let's substitute the numbers into the system of equations

$$\begin{cases} I_1 + I_3 = I_2, \\ I_1 \cdot 15 + I_2 \cdot (10 + 20) = 60, \\ I_1 \cdot 15 - I_3 \cdot 10 = 60 - 20. \end{cases}$$

## CALCULATION OF THE SYSTEM OF EQUATION

$$\begin{cases} I_1 + I_3 = I_2, \\ I_1 \cdot 15 + I_2 \cdot 30 = 60, \\ I_1 \cdot 15 - I_3 \cdot 10 = 40. \end{cases}$$

from the second equation

$$I_2 = \frac{60 - 15 \cdot I_1}{30} = 2 - 0,5 \cdot I_1$$

from the third equation

$$I_3 = \frac{15 \cdot I_1 - 40}{10} = 1,5 \cdot I_1 - 4$$

# CALCULATION OF THE SYSTEM OF EQUATION

let's substitute I2 and I3 in the first equation

$$I_1 + 1,5 \cdot I_1 - 4 = 2 - 0,5 \cdot I_1$$

we will move the terms that are multiplied by  $I_1$  to the left, and those that are not multiplied to the right

$$I_1 + 1,5 \cdot I_1 + 0,5 \cdot I_1 = 2 + 4$$

let's add similar terms

$$3 \cdot I_1 = 6$$



# CALCULATION OF THE SYSTEM OF EQUATION

let's calculate  $I_1$

$$I_1 = \frac{6}{3} = 2 \text{ (A)}$$

let's calculate  $I_2$

$$I_2 = 2 - 0,5 \cdot I_1 = 2 - 0,5 \cdot 2 = 2 - 1 = 1 \text{ (A)}$$

let's calculate  $I_3$

$$I_3 = 1,5 \cdot I_1 - 4 = 1,5 \cdot 2 - 4 = 3 - 4 = -1 \text{ (A)}$$

# TASK

(independent work)

Complete a system of equations according to Kirchhoff's rules

